

K40 2000

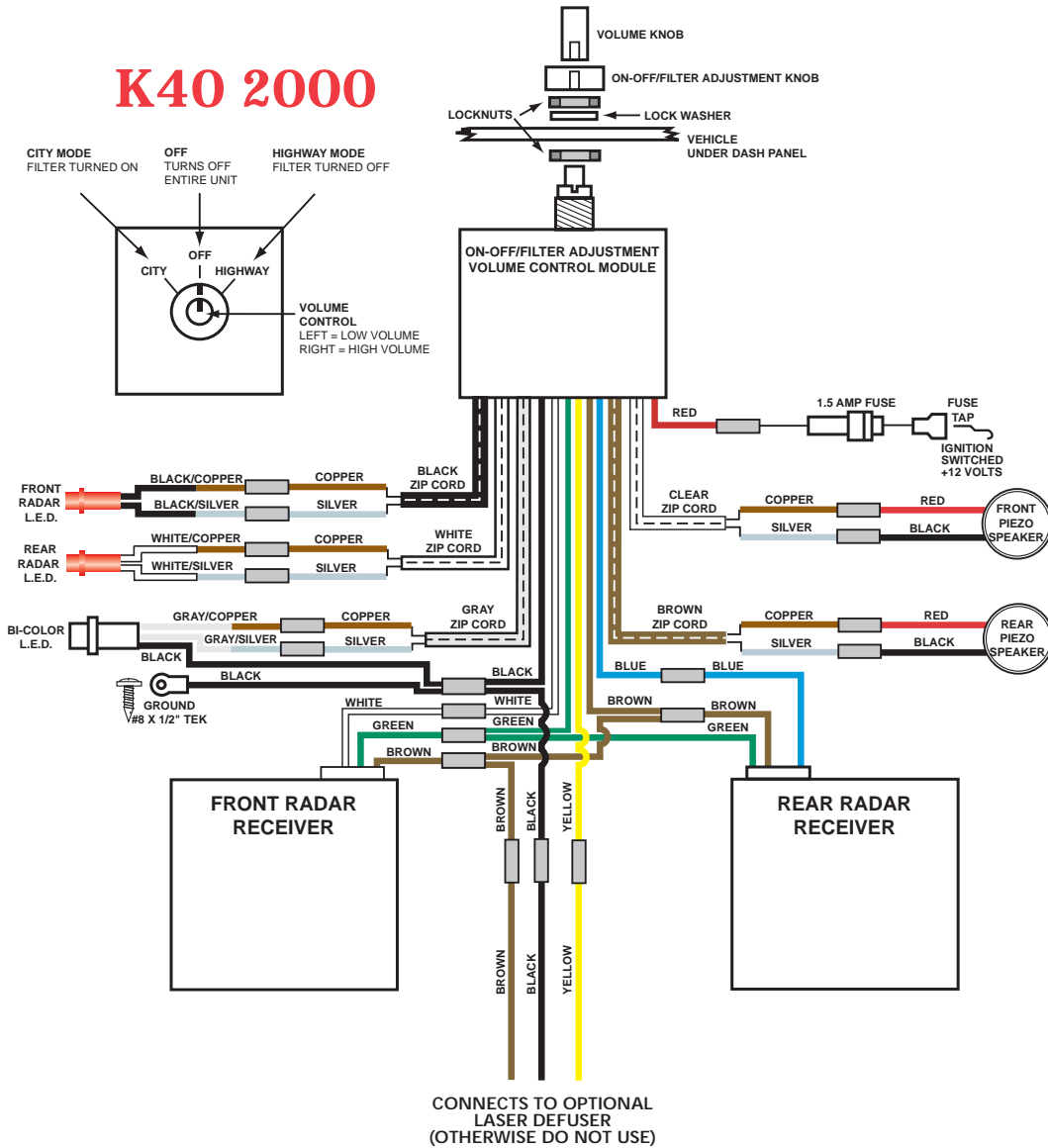

K40 1000

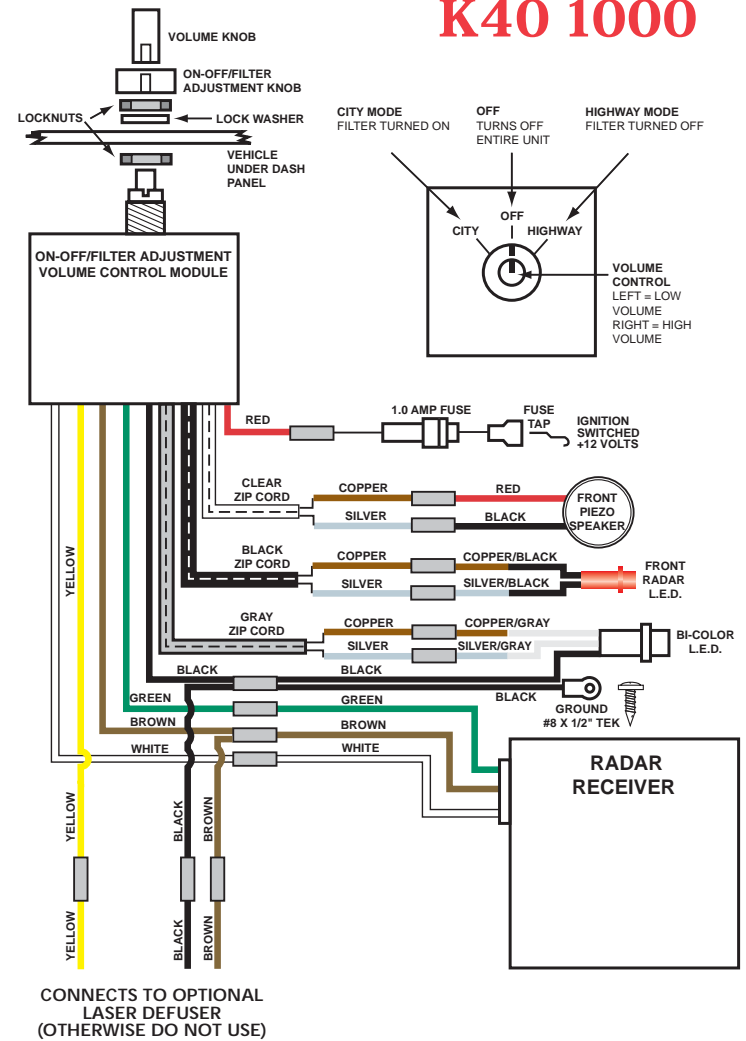

IGNITION AND GROUND

1. Use a test meter to locate an ignition on source with +12 volts when ignition key is both on and cranking.
2. Connect the black control module wire to a solid chassis ground under the dash using the provided ring terminal and silver self-tapping screw.

K40 2000P

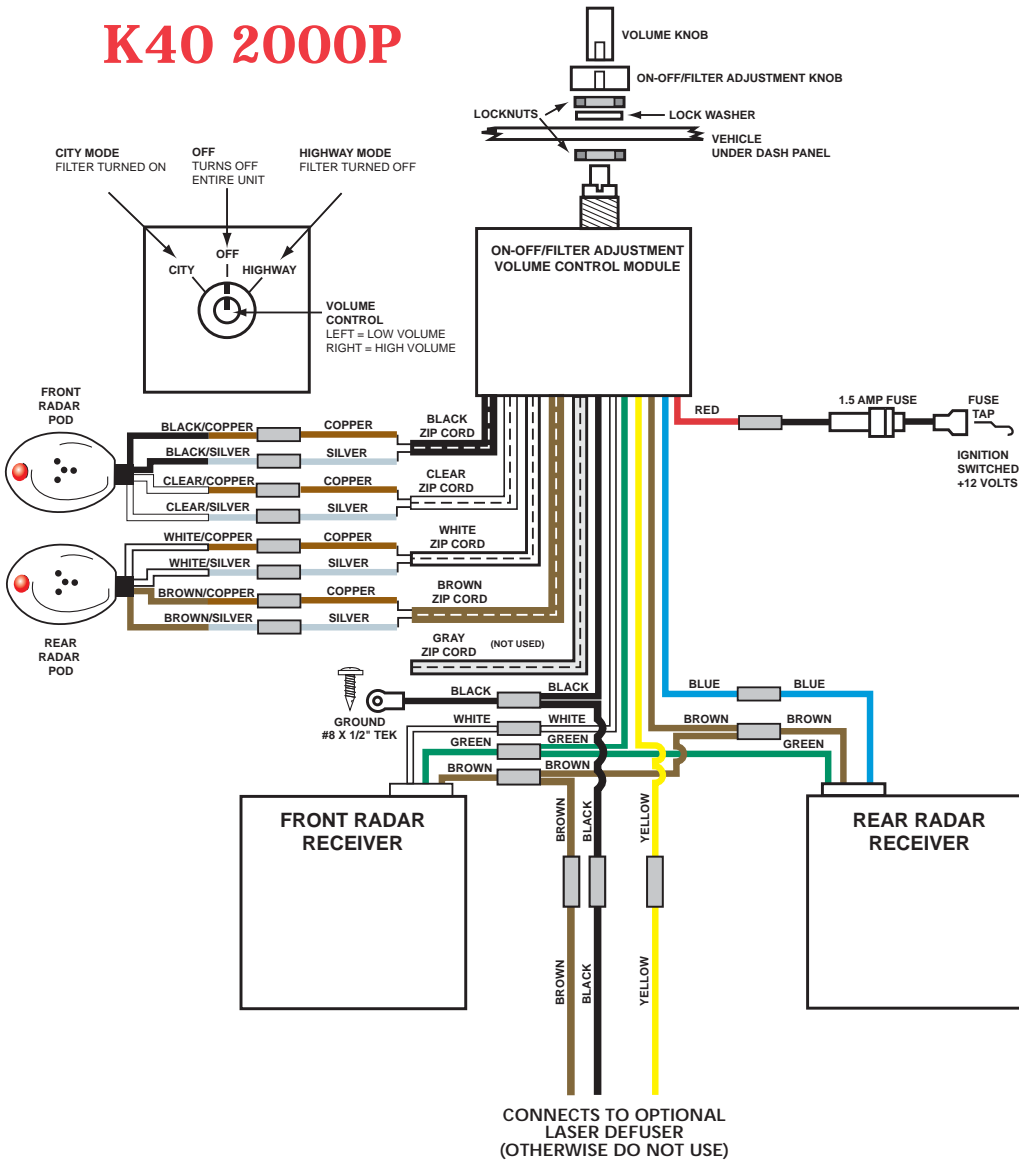

K40 1000P

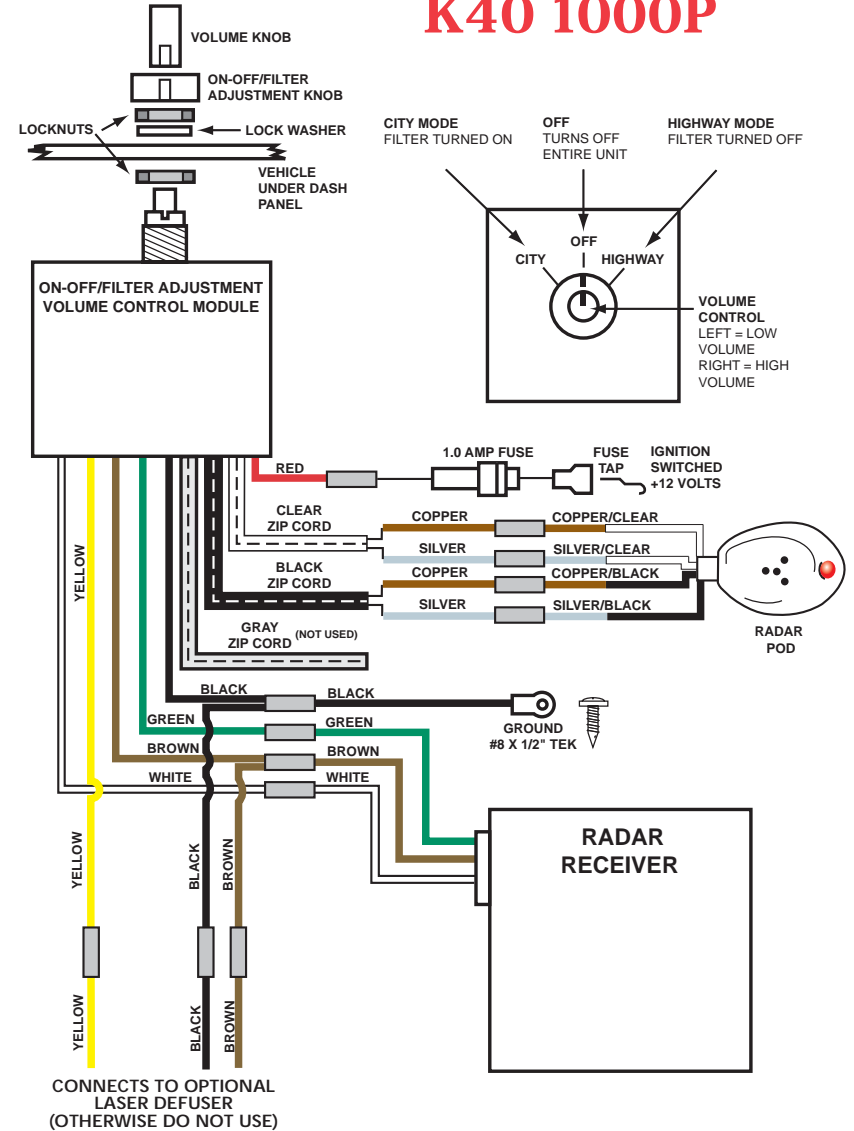

IGNITION AND GROUND

1. Use a test meter to locate an ignition on source with +12 volts when ignition key is both on and cranking.
2. Connect the black control module wire to a solid chassis ground under the dash using the provided ring terminal and silver self-tapping screw.